

Manufactured by
Delichon Limited
1 The Clayfields
Sandleheath Industrial Estate
Old Brickyard Road
Fordingbridge
Hampshire
SP6 1PA
UK

e-mail: office@delichon.uk

Website: www.delichon.uk

Tel. +44 (0)1725 519 405

EU Authorised Representative
Delichon Europe Ltd
Century House
Harold's Cross
Dublin 6W
Dublin
Ireland

e-mail: eu@deltabuggy.com

Your Delta Buggy has a unique serial number, which can be found on a silver label on the rear axle – please quote this number when contacting Delichon about your buggy.



If a Delta is to be disposed of all components and materials must be recycled or disposed of correctly, in accordance with national regulations.

DELTA TRAIL

INSTRUCTION MANUAL

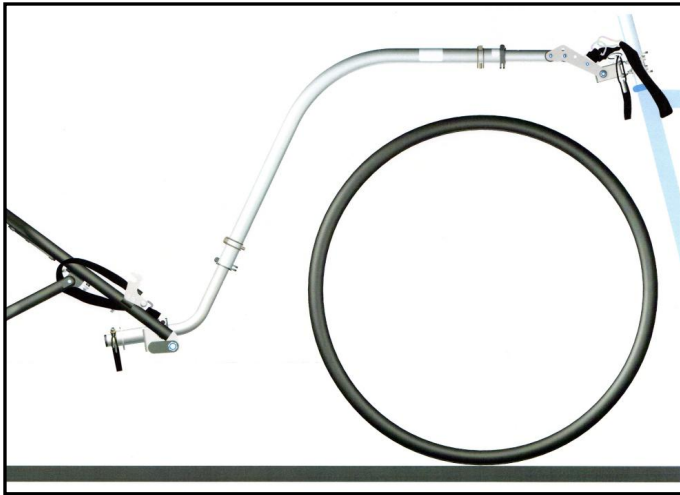

**PLEASE READ BEFORE USING YOUR DELTA
TRAIL AND KEEP IN A SAFE PLACE FOR FUTURE
REFERENCE**

DESCRIPTION

The Delta Trail is designed as an accessory to the Delichon Delta Buggy and should not be used with any other product. The Delta Trail allows the Delta Buggy to be towed behind a bicycle.



IMPORTANT SAFETY NOTES



◆ CYCLING WITH A TRAILER, AND CYCLING IN GENERAL CAN BE HAZARDOUS. FAILURE TO OBSERVE SAFETY INSTRUCTIONS COULD RESULT IN SERIOUS INJURY OR DEATH.

◆ Inspect and maintain your bicycle, Delta buggy and tow components regularly. See pre-use safety checks and maintenance instructions.

◆ If any part is damaged or fails to operate correctly do not continue to use the Delta Buggy or Delta Trail. Read the instructions and contact Delichon for advice if necessary.

◆ Because of the additional weight, a bicycle with a trailer is heavier and less responsive. Allow more stopping distance and manoeuvring space and avoid getting too close to kerbs or other obstacles.

◆ You child should always wear a helmet and be securely strapped into the buggy with the lap and shoulder harness.

◆ Make sure children keep their arms in the buggy.

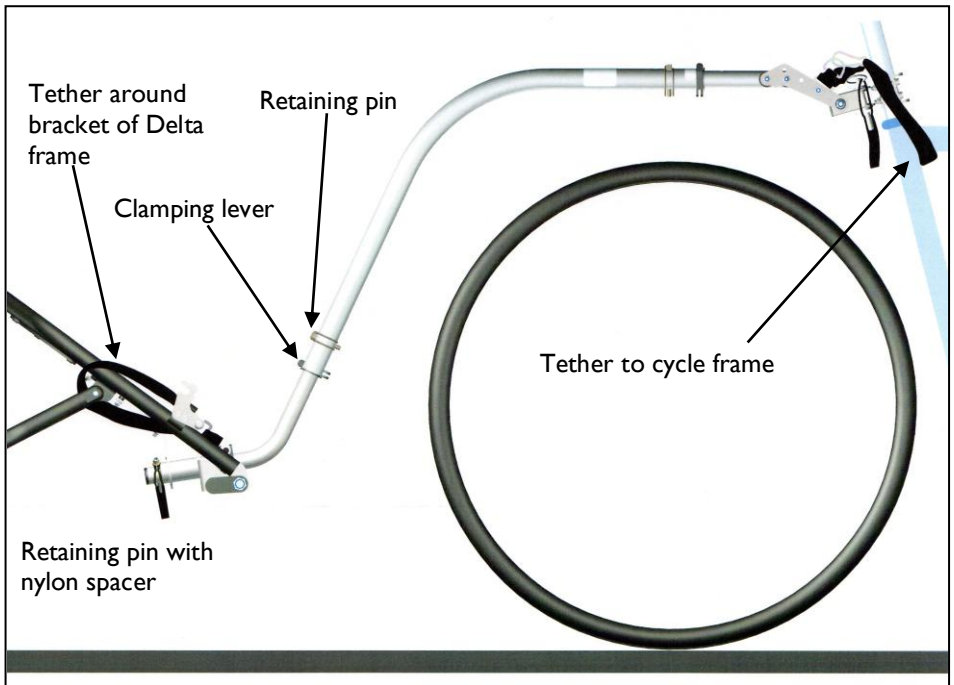

◆ **TETHER THE TOW BAR TO THE CYCLE FRAME AND THE DELTA FRAME.**

◆ **MAKE SURE THAT ALL OF THE RETAINING PINS ARE SECURE AND THE CLAMPS TIGHT.**



CHECK BEFORE EACH RIDE



- ◆ **Your cycle brakes are in good working order.**
- ◆ **Tyres are inflated to recommended pressure.**
 - ◆ **Safety tethers are in place.**
- ◆ **Child secured with lap belt and shoulder straps.**
- ◆ **All connections in tow bar are secured with retaining pins AND clamps or tethers.**
- ◆ **Passenger and cyclist have helmets.**

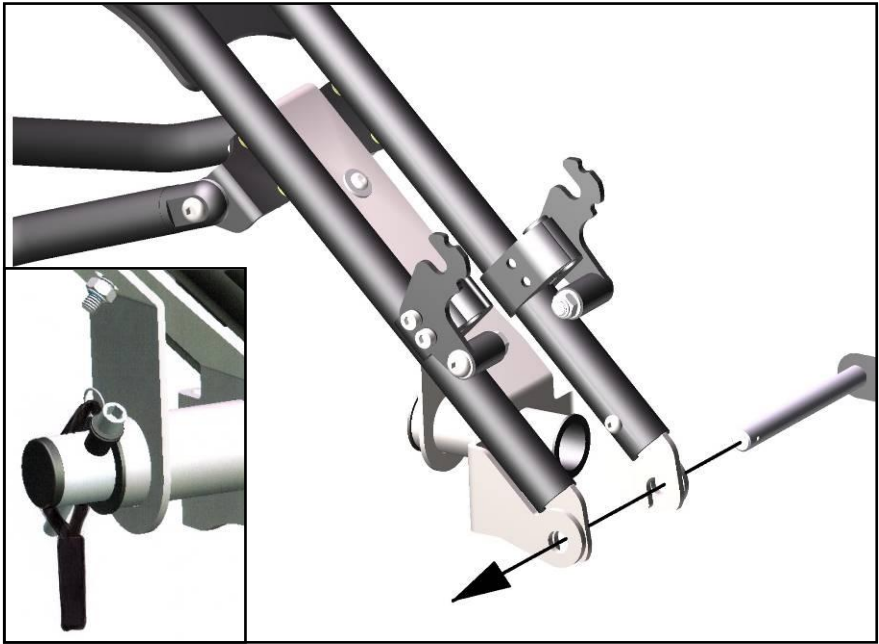

ADJUSTING THE TOW BAR

Slide the bottom end of the tow bar into the trail bracket on the Delta. Secure the tow bar to the Delta with the retaining pin that has a nylon spacer. Loop the bungee cord over the end of the pin to keep it in place.

Slot the hinge block on the end of the tow bar into the tow hitch on the saddle post and secure with the 8mm retaining pin. Loop the bungee cord over the end of the pin to keep it in place.

The top section of the tow bar needs to be approximately horizontal; the angle plates can be used downwards (as shown) or with the ends upwards, to suit the cycle frame.

The adjustable sections of the tow bar are attached with a retaining pin and a clamp.

Adjust the length of the top section of tow bar to give clearance at the back of the wheel.

Adjust the lower section of the tow bar so that the top section is approximately horizontal.

- ◆ **Make sure that your bicycle brakes are in excellent working order.**
- ◆ **Make sure children do not bounce or lean while towing, the weight shift could tip the trailer.**
- ◆ **Set the park brakes when transferring children in or out.**
- ◆ **Make sure that the tyres are fully inflated.**
- ◆ **Check all attachments before each ride, and always fasten the safety tethers.**
- ◆ **Observe recommended speed limits; a maximum of 15mph on smooth straight surfaces and 5mph or less when turning or on uneven surfaces.**
- ◆ **The use of a mirror on your bicycle is recommended.**



WARNING

TRAILERS CAN TIP OVER CAUSING DAMAGE AND INJURY TO PASSENGERS. AVOID THE CAUSES OF TIP-OVER, ESPECIALLY;

- ◆ **HITTING POTHoles, CURBS OR OTHER OBSTRUCTIONS.**
- ◆ **TAKING TURNS TOO FAST.**
- ◆ **CHILDREN LEANING OR BOUNCING.**
- ◆ **SUDDEN SWERVING**
- ◆ **IMPROPER TYRE INFLATION**

- ◆ **ALWAYS MAKE SURE THAT THE ROLL-BAR IS SECURELY ATTACHED.**

FITTING THE ROLL-BAR

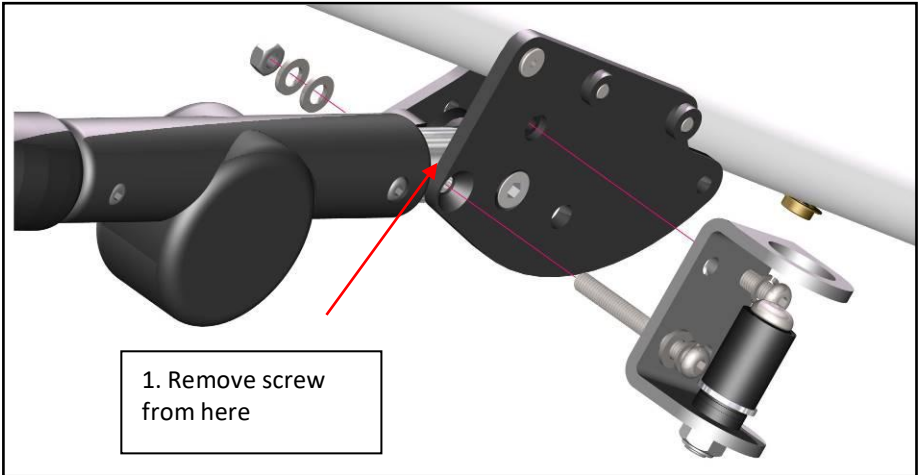

1. Remove the uppermost handle fixing screw from one of the handle plates; you will need a 4mm hexagon key and a 10mm spanner.
2. Attach the roll bar bracket to the handle plate as shown. The 20mm screw goes into an inset on the handle plate.
3. Repeat on the other side.

4. Slot the ends of the roll bar into the brackets on the frame; depress the button clips to get the frame all the way on. The buttons locate under the top part of the bracket when the bar is fully engaged.

The roll-bar fits over the sun-hood.

The rain cover fits over the roll bar.

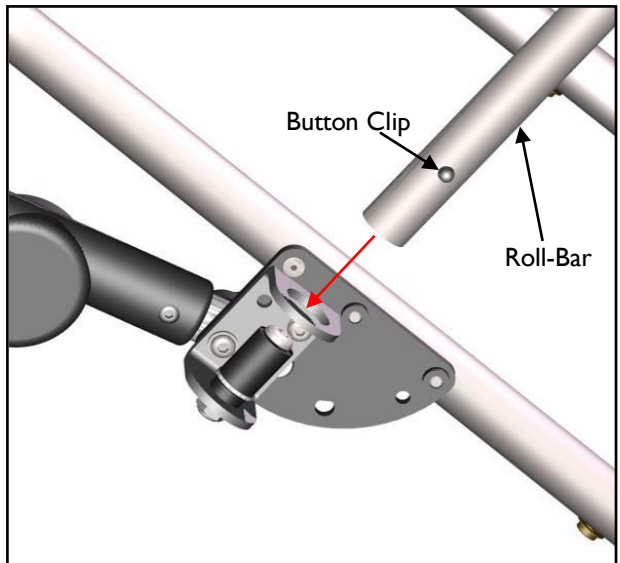

TO THE BICYCLE

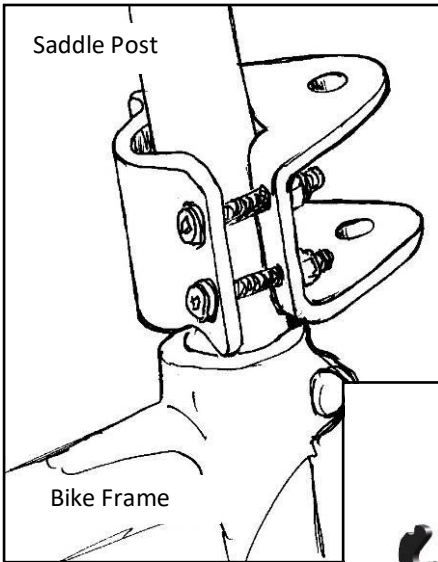

Attach the tow hitch bracket to the saddle post. You will need a 4mm hexagon key and a 10mm spanner. Two sets of screws are provided; use the length most suited to your saddle post; the ends of the screws need to protrude slightly from the nuts. Tighten the screws until the bracket is firmly held in place; it does not need to be extremely tight. The bracket should be fitted as close as possible to the bike frame.

FITTING THE TRAIL BRACKET TO THE DELTA BUGGY

Remove the front wheel of the Delta buggy.

Latch the back plate of the trail bracket under the bracket on the front forks as shown right.

Rotate the bracket so that the holes line up with the front wheel slots.



Insert the quick release pin through the holes and the front wheel slots; make sure that the securing balls on the end of the pin are clear of the tow bracket.